

# Machining the Andrex axle to fit an O-ring seal

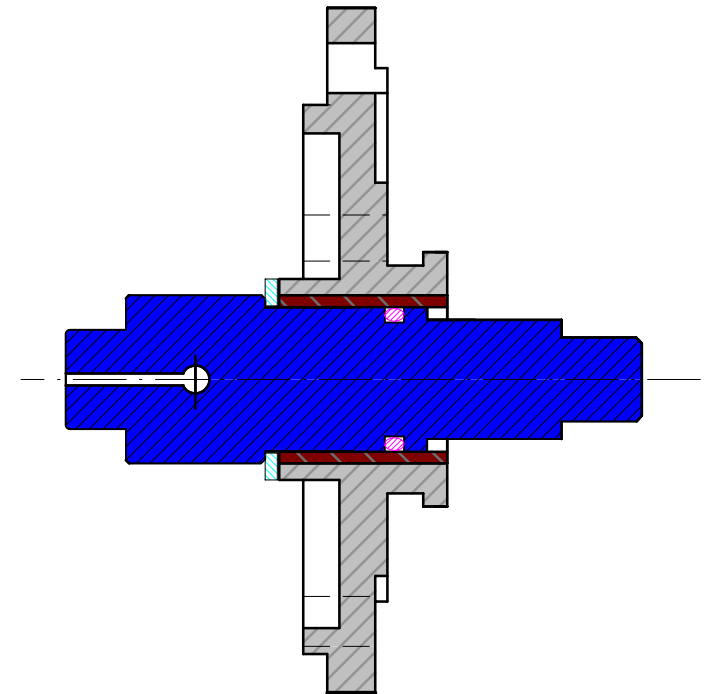
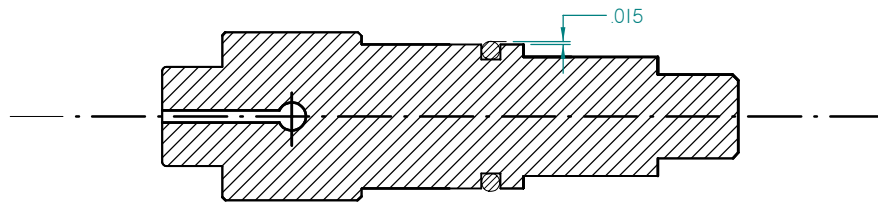
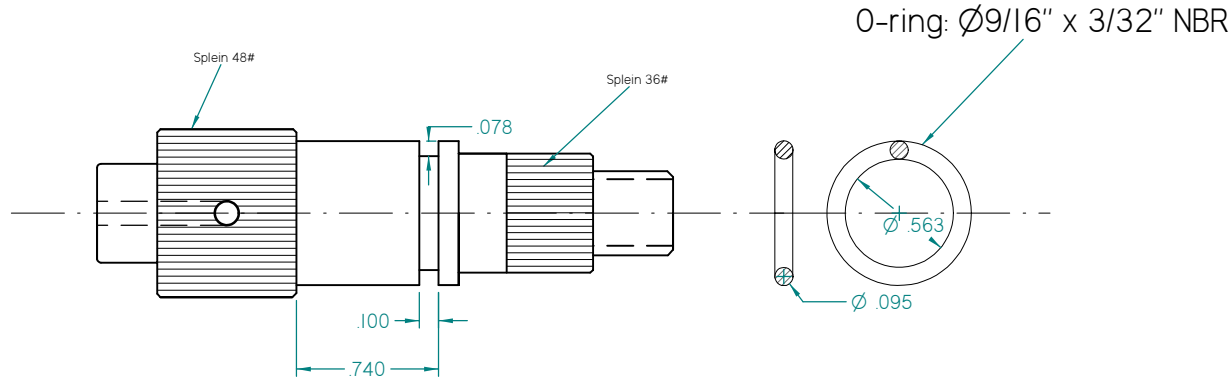

DRN	OH	DATE	07.11.20	REV.	A				
OLA HJORUNGDAL Hjørungdalen 43 6063 Hjørungevag NORWAY Pht: +47 9170653 E-mail: ola.hjorungdal@tussa.com						PROJECT: ANDREX SHOCK ABSORBERS Type TE1, INTERNAL AXLE MODIFIED FOR O-RING SEAL DRAWING NO: 071120.OH DIM: Inc. SCALE: 1:2			